

Change the way you build for the better with **trusscore**

Lightweight, low maintenance wall and ceiling panel systems that are designed to last a lifetime.



Contents

What is Trusscore?	5
Residential Applications	6
Commercial Applications	10
Agricultural Applications	14
Trusscore Wall&CeilingBoard	18
Wall&CeilingBoard vs. Drywall	20
Wall&CeilingBoard vs. FRP	23
Trusscore SlatWall	24
SlatWall vs. MDF	26
SlatWall vs. PVC SlatWall	29
RibCore by Trusscore	30
NorLock by Trusscore	32
Trusscore Trims	34
NorLock by Trusscore Trims & Accessories	37
Trusscore Stocking Dealer Program	40
Need More Resources?	42





Trusscore Wall&CeilingBoard & Trusscore SlatWall in Garage



Trusscore Wall&CeilingBoard in Office Cafeteria



Trusscore Wall&CeilingBoard in Bathroom & Hallway



Trusscore Wall&CeilingBoard & Trusscore SlatWall in Garage



Trusscore Wall&CeilingBoard in Commercial Warehouse

What is Trusscore?

Trusscore is changing how people build buildings and the environmental footprint left behind when they do by making high-performing wall and ceiling products that are functional, beautiful, and fully recyclable. Trusscore is the perfect fit for any room or facility that requires a crisp, clean, long-lasting finish.

The Trusscore product line replaces conventional wall, ceiling, and penning systems made from plywood, painted drywall, and fiberglass reinforced plastic (FRP) panels in a broad range of residential, commercial, and agricultural applications. Products include:



Trusscore® Wall&CeilingBoard™

Trusscore Wall&CeilingBoard are interlocking, interior PVC wall and ceiling panels that are lightweight, low maintenance, and outperform the competition.

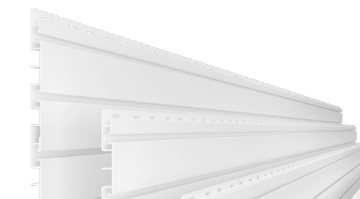

Trusscore® SlatWall™

Trusscore SlatWall is a high-strength, on-the-wall organization system that's easy to install and seamlessly integrates with Trusscore Wall&CeilingBoard.



NorLock™ by Trusscore®

NorLock by Trusscore are durable freestanding, interlocking divider planks for interior walls, non-load bearing partitions, and penning.



RibCore™ by Trusscore®

RibCore by Trusscore are high-strength PVC corrugated panels that are durable, cost effective, and easy to install and maintain.

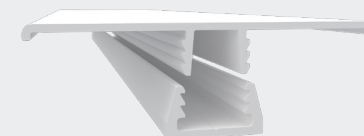

Trusscore® Trims

Trusscore offers a wide range of PVC-based framing, finishing, and specialty trims to help you complete any project involving Trusscore Wall&CeilingBoard, Trusscore SlatWall, and RibCore.



Residential Applications

Made from PVC, pre-finished Trusscore Wall&CeilingBoard panels install with ease and provide a bright, clean finish to maximize the lighting in any room all while being waterproof and impact resistant.

It's the perfect alternative to drywall — in fact, it **installs 4x faster** without the mess — and can be seamlessly combined with Trusscore SlatWall to help you create storage space anywhere.

trusscore Residential Applications

Applications Include:

- ✓ Bathrooms
- ✓ Basements
- ✓ Boathouses
- ✓ Garages
- ✓ Home Organization
- ✓ Interior Spaces
- ✓ Kitchens
- ✓ Laundry Rooms
- ✓ Multi-Residential Facilities
- ✓ Sheds
- ✓ Sheltered Exterior Ceilings
- ✓ Utility Rooms

Suggested Products:

- ✓ Trusscore Wall&CeilingBoard
- ✓ Trusscore SlatWall
- ✓ RibCore by Trusscore
- ✓ Trusscore Trims



Trusscore Wall&CeilingBoard in Residential Basement



Trusscore Wall&CeilingBoard in Residential Bathroom



Trusscore Wall&CeilingBoard in Residential Garage



Strength & Durability

Once installed, drywall can easily be damaged, forcing you to fill in holes or cracks over time. With Trusscore, you never have to worry about damage: The panels are scratch, dent, and impact resistant, making them perfectly suited for high-traffic areas in your home.



Lightweight & Easy to Install

Trusscore Wall&CeilingBoard is made for DIYers. The pre-finished panels weigh 40% less than drywall and — thanks to their pre-punched screw flange and tongue and groove interlocking system — can be installed four times faster with no special skills or tools required.



Moisture & Water Resistant

If drywall is exposed to humidity or water, it will eventually stain, bubble, sag, or bulge. Left alone, it will grow mold or mildew. Trusscore products, on the other hand, are 100% water and moisture resistant, so water will roll right off the panels, and they'll never grow mold or mildew.



Easy to Clean

Trusscore panels have a smooth, stain resistant surface that can be regularly wiped cleaned with soap and water to keep them looking as good as the day they were installed. For tougher scuffs, you can use a Magic Eraser or pressure washer without any worry of damaging the panels.



Bright & Versatile

Bright Trusscore panels are highly reflective and can maximize any available natural or fixture lighting in your space. They're also available in white and gray and can be installed horizontally or vertically, allowing you to play with shapes, colors, and patterns for more interesting design concepts.



Instant Organization

Trusscore Wall&CeilingBoard seamlessly integrates with Trusscore SlatWall to create a high-strength, on-the-wall storage solution. Trusscore SlatWall can be installed as a track, section, half wall, or full wall, and can immediately be accessorized with snap-in hooks, baskets, and shelves to meet your storage needs.



Commercial Applications

Trusscore interlocking wall and ceiling panel systems are designed to replace drywall, plasterboard, and FRP in commercial spaces where durability, moisture resistance, and cleanability are among top concerns.

trusscore Commercial Applications

Applications Include:

- ✓ Air Hangars
- ✓ Car & Truck Washes
- ✓ Cleanrooms
- ✓ Dog Kennels
- ✓ Food Processing Facilities
- ✓ Grow Rooms
- ✓ Healthcare Facilities
- ✓ Kitchens
- ✓ Office Spaces
- ✓ Recreational Facilities
- ✓ Temporary Partition Walls
- ✓ Workshops

Suggested Products:

- ✓ Trusscore Wall&CeilingBoard
- ✓ Trusscore SlatWall
- ✓ NorLock by Trusscore
- ✓ RibCore by Trusscore
- ✓ Trusscore Trims



Trusscore Wall&CeilingBoard & Trusscore SlatWall in Office



Trusscore Wall&CeilingBoard & Trusscore SlatWall in Airplane Hangar



Trusscore Wall&CeilingBoard & NorLock by Trusscore in Commercial Carwash



Industry-Leading Durability

The mechanical strength of PVC combined with the unique truss design and ½" thickness of Trusscore Wall&CeilingBoard means panels will last longer than 0.375in thick alternatives on the market. The abrasion resistance of PVC also means that the panels are impact-resistant and can stand up to contact without showing dents, cracks, or damage.



Lightweight & Easy to Install

Weighing 40% less than drywall, Trusscore Wall&CeilingBoard can easily be handled by one person, significantly reducing labor costs on your project. Panels also have a pre-punched screw flange and a tongue and groove interlocking system, allowing it to be installed four times faster than drywall and twice as fast as FRP.



Moisture & Water Resistant

Trusscore products are 100% moisture and water resistant. The presence of PVC means the panels shed water and won't absorb airborne moisture, so they won't degrade or deteriorate in wet or damp environments, and they won't support the growth of mold or mildew.



Antimicrobial & Easy to Clean

Trusscore panels have a smooth, non-porous finish that makes it tough for bacteria, mold, or viruses to take hold. The panels are also easy to clean and disinfect — they can't be harmed by detergent or chemical cleaners and can be repeatedly pressure washed.



High Light Reflectivity

White Trusscore products have a light reflectivity value of 0.90, meaning they reflect 90% of the light that hits them. This helps you maximize any available natural and fixture lighting in your space, reducing overall lighting costs and boosting your facility's energy efficiency.



Environmentally Friendly

Trusscore products have a service life of up to 100 years, are 100% recyclable, and can be recycled six to seven times to make new PVC-based building materials. Since our products are recyclable and reusable, Trusscore can contribute to LEED certification under the Materials and Resources category.



Agricultural Applications

Trusscore wall, ceiling, and penning products are a high-strength, long-lasting, and hygienic alternative to FRP, concrete, plywood, and OSB systems in agricultural facilities that are fully CFIA, USDA, and FDA compliant.

trusscore Agricultural Applications

Applications Include:

- ✓ Barns
- ✓ Cleanrooms
- ✓ Dairy Facilities
- ✓ Dog Kennels
- ✓ Food Processing Facilities
- ✓ Grow Rooms
- ✓ Pork Facilities
- ✓ Horse Stables
- ✓ Poultry Facilities
- ✓ Workshops

Suggested Products:

- ✓ Trusscore Wall&CeilingBoard
- ✓ Trusscore SlatWall
- ✓ NorLock by Trusscore
- ✓ RibCore by Trusscore
- ✓ Trusscore Trims

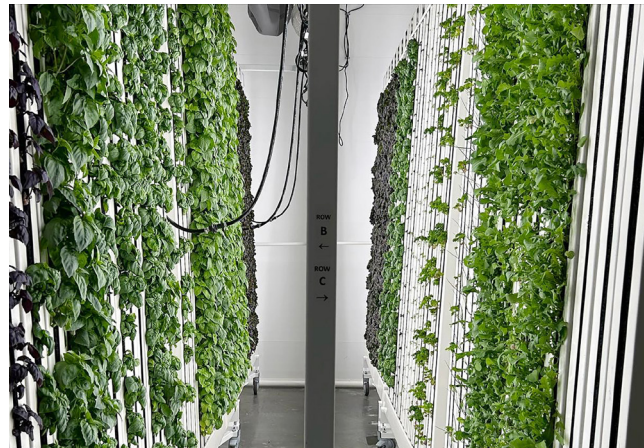

Trusscore Wall&CeilingBoard in Indoor Grow Facility



Trusscore Wall&CeilingBoard in Dairy Cleanroom



Trusscore Wall&CeilingBoard in Poultry Facility



Industry-Leading Durability

The mechanical strength of PVC combined with the unique truss and ½" design of Trusscore means that panels can outlive the buildings they're installed in and withstand frequent bumps from large animals. The abrasion resistance of PVC also means that the panels are impact-resistant and can stand up to contact without showing dents, cracks, or damage.



Enhanced Biosecurity

Antimicrobial Trusscore products are designed to prevent, contain, and destroy bacteria, fungi, and viruses to keep your facility infection- and disease-free. Per third party testing (ISO 846:2019), Trusscore Wall&CeilingBoard provides complete protection against mold and bacteria.



Moisture & Water Resistant

Trusscore products are 100% moisture and water resistant. The presence of PVC means the panels shed water and won't absorb airborne moisture, so they won't degrade or deteriorate in wet or damp environments, and they won't support the growth of mold or mildew.



Cleanability

In agricultural spaces where cleanliness is critical for uninterrupted operations and productivity, durable and water resistant Trusscore products are built to last. All Trusscore products can withstand frequent use of soaps, cleaning agents, disinfectants, and sanitizers. They'll also stand up to repeated pressure washing with ease.



High Light Reflectivity

White Trusscore products have a light reflectivity value of 0.90, meaning they reflect 90% of the light that hits them. This helps you maximize any available natural and fixture lighting in your space boosting your agricultural facility's energy efficiency. In many agricultural applications, the highly reflective panels also help boost reproductive efficiency of livestock.



Complete Regulatory Compliance

Trusscore Wall&CeilingBoard, NorLock, and RibCore are fully compliant with the requirements set out by the Canadian Food Inspection Agency (CFIA), Food and Drug Administration (FDA), and U.S. Department of Agriculture (USDA) for food processing and commercial agricultural facilities. It also meets Current Good Manufacturing Practice (cGMP) facility requirements.

Trusscore® Wall&CeilingBoard™

Change the way you build for the better with Trusscore Wall&CeilingBoard — lightweight and low maintenance wall and ceiling panels that are designed to last a lifetime.

Pre-finished Trusscore Wall&CeilingBoard panels install with ease and provide a bright, clean finish to maximize the lighting in any space all while being waterproof and impact resistant. It's the perfect alternative to traditional drywall and fiberglass reinforced plastic (FRP) systems in a broad range of residential, commercial, and agricultural applications.

Applications: ✓ Residential ✓ Commercial ✓ Agricultural

Features & Specifications

- ▮ Available in 8, 10, 12, 14, 16, and 20ft lengths*
- ▮ Available in white and gray
- ▮ 16in wide panels match typical framing spacing
- ▮ Industry-leading ½" thick panels have a unique internal truss design for high-strength and rigidity
- ▮ Pre-punched screw flange and tongue and groove interlocking system for easy installation and a seamless finish
- ▮ Installs directly to bare studs or over drywall
- ▮ "Class A" fire rating (ASTM E84/ULC S102)
- ▮ White panels have a light reflectivity value of 0.90
- ▮ Provides complete protection against the growth of bacteria, fungi, and viruses (ISO 846:2019)
- ▮ Low VOC compliant per the California Department of Public Health Standard Method v1.2 testing standard
- ▮ CFIA, USDA, FDA, and cGMP compliant for use in food processing and commercial agricultural facilities

**Custom lengths available upon request*

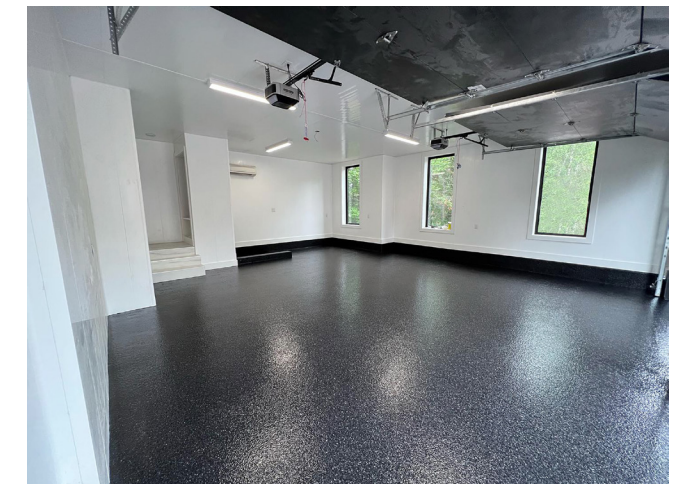
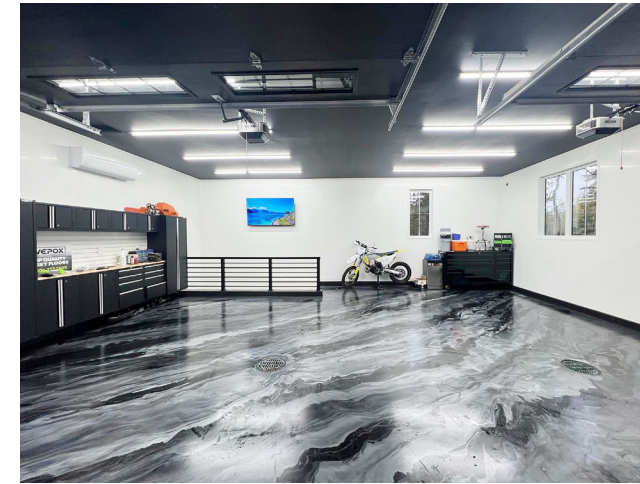
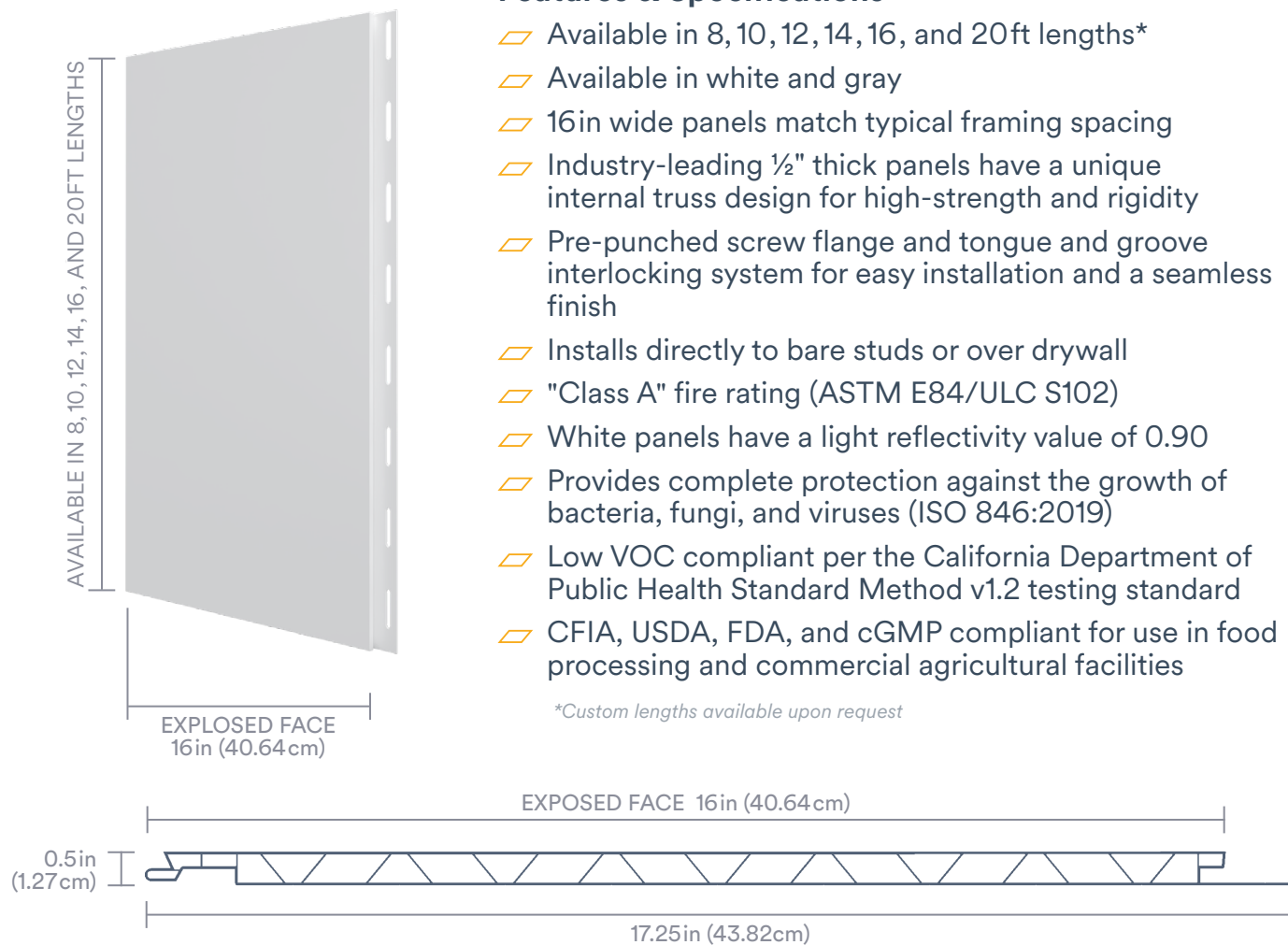

PANEL LENGTH	PANEL DIMENSIONS	PANEL COLOR	PRODUCT #
8ft	96in x 16in x 0.5in (243.84cm x 40.64cm x 1.27cm)	White	TC1608
		Gray	GTC1608
10ft	120in x 16in x 0.5in (304.8cm x 40.64cm x 1.27cm)	White	TC1610
		Gray	GTC1610
12ft	144in x 16in x 0.5in (365.76cm x 40.64cm x 1.27cm)	White	TC1612
		Gray	GTC1612
14ft	168in x 16in x 0.5in (426.72cm x 40.64cm x 1.27cm)	White	TC1614
		Gray	GTC1614
16ft	192in x 16in x 0.5in (487.68cm x 40.64cm x 1.27cm)	White	TC1616
		Gray	GTC1616
20ft	240in x 16in x 0.5in (609.6cm x 40.64cm x 1.27cm)	White	TC1620
		Gray	GTC1620

trusscore Wall&CeilingBoard vs. Drywall

DRYWALL	TRUSSCORE WALL&CEILINGBOARD
EASE OF INSTALLATION	
✗ Sheets of drywall are heavy, awkward to work with, and often require two people to install – especially on tricky ceiling installations. Plus, customers have to mud, tape, prime, and paint before the job is done.	✓ Pre-finished Trusscore Wall&CeilingBoard panels weigh 40% less than drywall and install four times faster with no special tools or skills required.
MOISTURE & WATER RESISTANCE	
✗ Stains, bubbling, peeling paint, sagging, and bulging are all visible signs that drywall has water damage. Left alone, mold can begin growing in 24 to 48 hours.	✓ Made from PVC, Trusscore Wall&CeilingBoard panels are 100% water and moisture resistant — they're designed to shed water and will never grow mold or mildew.
STRENGTH & DURABILITY	
✗ Drywall isn't impact resistant and in high traffic and humid areas, you'll likely notice scuffs, holes, cracks, dents, screw pops, and tell-tale signs of water damage over time.	✓ Trusscore wall and ceiling panels are scratch, dent, and damage resistant and are designed to outlive the buildings they're installed in.
CLEANABILITY	
✗ Since it's so absorbent, customers must be careful not to overdo it with soap and water when cleaning painted drywall. However, some scuffs will be so stubborn it requires a full-scale drywall repair.	✓ The smooth, non-porous surface of Trusscore Wall&CeilingBoard means panels can be easily and repeatedly cleaned with soap and water, chemical cleaners, and pressure washing.
SUSTAINABILITY	
✗ An estimated 75% of drywall ends up in landfills, where it produces smelly hydrogen sulfide gas and leaches dangerous sulfates into the groundwater.	✓ Trusscore Wall&CeilingBoard is 100% recyclable and can be reground and reused to make new materials, extending our product's lifecycle.
MATERIAL COSTS	
✗ Drywall is a commodity product that can be purchased for a whole room for under \$200. However, any money saved at the checkout has to be used to pay for extensive hourly labor to install the product. Plus, homeowners can expect to spend even more money maintaining drywall over the course of its lifetime.	✓ Trusscore Wall&CeilingBoard is a premium product that's designed to minimize the total cost of installation materials, labor, and maintenance all while never having to be repaired replaced. When compared to drywall, customers will save 55% in total cost of ownership over the life of the product.





trusscore Wall&CeilingBoard vs. FRP

FRP	TRUSSCORE WALL&CEILINGBOARD
EASE OF INSTALLATION	
<p>✗ FRP is difficult to handle, difficult to cut, and requires a multi-step installation process — including the use of messy glue — that calls for multiple skilled installers.</p>	<p>✓ Unlike FRP, Trusscore Wall&CeilingBoard doesn't require additional backing material or messy glue to install. The pre-finished panels come ready to install, with just a few screws and common tools required, for a 33% lower installed cost.</p>
MOISTURE & WATER RESISTANCE	
<p>✗ FRP is said to be moisture and water resistant, but the seams are penetrable. Over time, moisture can cause the plastic to separate from its substrate and become a vector for mold and mildew.</p>	<p>✓ Trusscore Wall&CeilingBoard panels are 100% water and moisture resistant — the interlocking tongue-and-groove system creates a watertight seal and the presence of PVC means the panels will shed water.</p>
SUSTAINABILITY	
<p>✗ FRP is not easily recycled when you consider the backing material and glue, which adds complexity to recycle.</p>	<p>✓ Unlike FRP, Trusscore products are 100% recyclable and the limited waste product from install can be reground and reused to make new materials.</p>
INDOOR ENVIRONMENTAL QUALITY	
<p>✗ FRP requires glue to install, and the glue is a known source of volatile organic compounds (VOCs) that can jeopardize indoor air quality.</p>	<p>✓ Trusscore products are all low-VOC compliant, including low formaldehyde, meaning it won't off-gas and ensures a safe and healthy space for occupants.</p>

Trusscore® SlatWall™

Clear the clutter with Trusscore SlatWall — an on-the-wall organization system that's easy to install, built to last, and seamlessly integrates with Trusscore Wall&CeilingBoard to completely transform any space.

Trusscore SlatWall is designed to help you instantly organize your home, garage, office, or workspace as soon as it's installed and gives you creative freedom to turn as much — or as little — of your wall into storage space. The 8ft long, interlocking panels can be installed as a track, section, half wall, or a full wall.

Applications: ✓ Residential ✓ Commercial ✓ Agricultural



Features & Specifications

- ▮ Available in 8ft lengths
- ▮ Available in white and gray
- ▮ Panels are 6in wide (7.25in including flange)
- ▮ Industry-leading 0.625in thick panels
- ▮ Pre-punched screw flange for quick and easy installation
- ▮ Supports up to 75lbs per square foot
- ▮ Seamlessly integrates with Trusscore Wall&CeilingBoard; the only product on the market to do so
- ▮ Non-proprietary design means panels are compatible with most slatwall accessories on the market

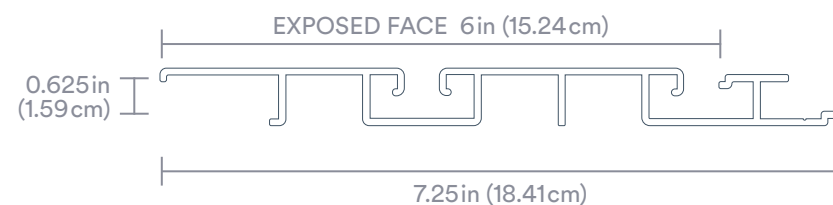
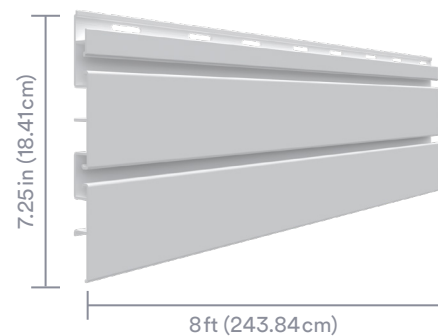

PANEL LENGTH	PANEL DIMENSIONS	PANEL COLOR	PRODUCT #
8ft	96in x 6in x 0.625in (243.84cm x 15.24cm x 1.5875cm)	White	TL1841608
		Gray	GTL1841608

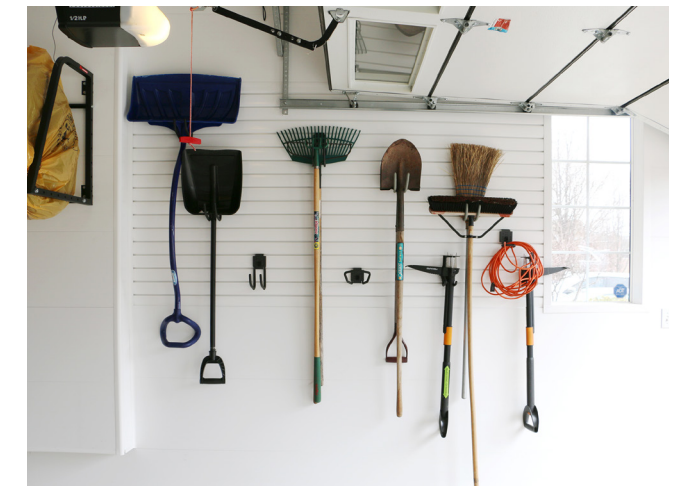
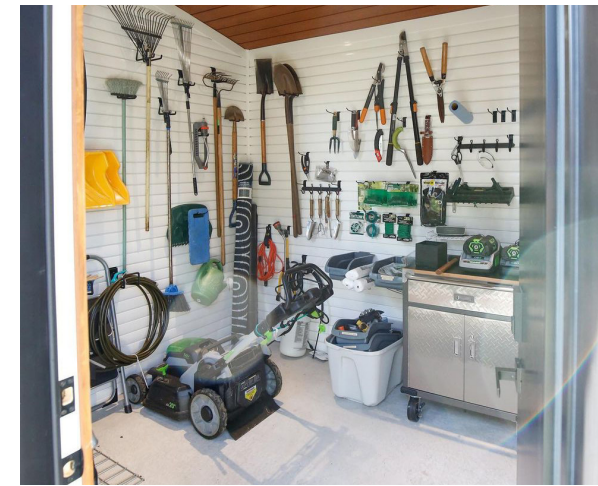

trusscore SlatWall vs. MDF

MDF	TRUSSCORE SLATWALL
EASE OF INSTALLATION	
✗ MDF is heavy and weighs even more than solid wood, so it requires at least two people to install it to a wall.	✓ Trusscore SlatWall is lightweight and easy to handle, with just one person needed for installation.
MOISTURE & WATER RESISTANCE	
✗ While the exterior of MDF is water resistant, the interior wood fibers will swell and mold if exposed to moisture.	✓ Trusscore panels are 100% resistant to water and moisture, and they'll never grow mold or mildew.
STRENGTH & DURABILITY	
✗ MDF is easy to damage and any damage is permanent — since it's not made of solid wood, MDF can't be sanded to hide dents or scratches.	✓ Just like Trusscore Wall&CeilingBoard, Trusscore SlatWall is scratch, dent, and damage resistant.
CLEANABILITY	
✗ MDF can only be cleaned with dish soap, warm water, and a damp soft cloth and must be thoroughly dried to prevent damage.	✓ Trusscore SlatWall can easily be cleaned with soap and water and can handle chemical detergents.





trusscore SlatWall vs. Other PVC Slatwall

OTHER PVC SLATWALL	TRUSSCORE SLATWALL
CUSTOMIZATION	
<p>✗ Other PVC slatwall systems are often sold in limiting kits, forcing customers to add storage on just a small section of their wall.</p>	<p>✓ Trusscore SlatWall panels can be installed as a track, section, half wall, or a full wall to meet storage needs both big and small.</p>
WALLBOARD INTEGRATION	
<p>✗ Other PVC slatwall doesn't integrate with other wall boards, requiring more work to fully finish a space.</p>	<p>✓ Trusscore SlatWall integrates with Trusscore Wall&CeilingBoard to create a seamless wall organization system.</p>
STORAGE CAPABILITIES	
<p>✗ Other PVC slatwall is often only compatible with its manufacturer's accessories, forcing customers to pay extra for proprietary products.</p>	<p>✓ Trusscore SlatWall is compatible with any standard 3in slatwall accessory so customers can organize their space their way.</p>
HIDDEN FASTENERS	
<p>✗ Other PVC slatwall products often have visible fasteners, which creates makes an installation look unfinished.</p>	<p>✓ Trusscore SlatWall panels have an interlocking tongue and groove system and pre-punched screw flange that hide fasteners for a seamless finish.</p>

RibCore™ by Trusscore®

Long-lasting, cost effective, and easy to install PVC corrugated panels.

RibCore by Trusscore is a high-strength wall and ceiling liner for industrial and commercial buildings, and agricultural confinement areas. The highly reflective panels are designed to maximize the lighting in any space, their durable surface can be repeatedly sanitized and pressure washed, and their water-resistant properties mean they'll never rot or rust.

Applications: ✓ Residential ✓ Commercial ✓ Agricultural



Features & Specifications

- ▢ Available in 10, 12, 16, and 20ft lengths*
- ▢ Reversible profile
- ▢ Easily cut with hand or power saws
- ▢ Installs directly to bare studs or over drywall
- ▢ Panels have a light reflectivity value of 0.90
- ▢ Provides complete protection against the growth of bacteria, fungi, and viruses (ISO 846:2019)
- ▢ Low VOC compliant per the California Department of Public Health Standard Method v1.2 testing standard
- ▢ CFIA, USDA, FDA, and cGMP compliant for use in food processing and commercial agricultural facilities
- ▢ Install with readily available wood (corrosion-resistant) screws with a minimum head diameter of 3/8in

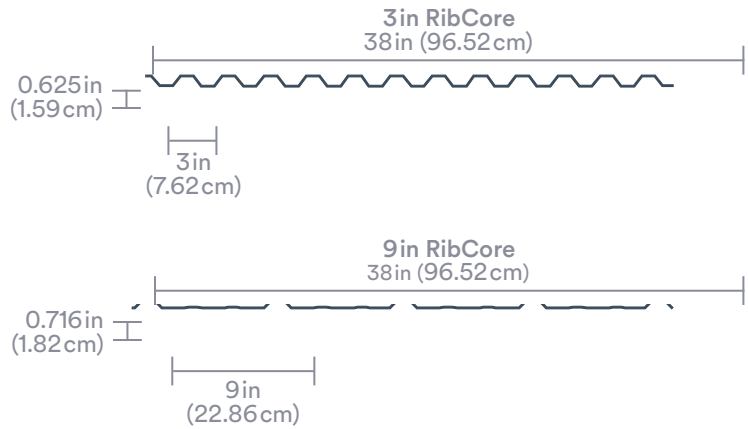
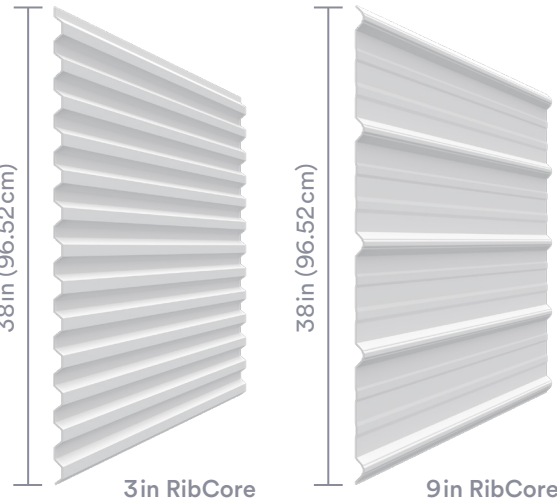

PRODUCT	MATERIAL THICKNESS	SHEET SIZE (WIDTH X LENGTH)	COVERAGE (WIDTH X LENGTH)	PRODUCT #
3in RibCore (7.62cm)	0.031in (0.079cm)	38in x 10ft 2in (96.52cm x 309.9cm)	36in x 10ft (91.44cm x 304.8cm)	RC3610
		38in x 12ft 2in (96.52cm x 370.8cm)	36in x 12ft (91.44cm x 365.8cm)	RC3612
		38in x 16ft 4in (96.52cm x 497.8cm)	36in x 16ft (91.44cm x 487.7cm)	RC3616
		38in x 20ft 4in (96.52cm x 619.8cm)	36in x 20ft (91.44cm x 609.6cm)	RC3620
9in RibCore (22.86cm)	0.035in (0.09cm)	38in x 10ft 2in (96.52cm x 309.9cm)	36in x 10ft (91.44cm x 304.8cm)	RC9-3610
		38in x 12ft 2in (96.52cm x 370.8cm)	36in x 12ft (91.44cm x 365.8cm)	RC9-3612
		38in x 16ft 4in (96.52cm x 497.8cm)	36in x 16ft (91.44cm x 487.7cm)	RC9-3616
		38in x 20ft 4in (96.52cm x 619.8cm)	36in x 20ft (91.44cm x 609.6cm)	RC9-3620

NorLock™ by Trusscore®

Durable freestanding divider planks for interior walls, non-load bearing partitions, and penning.

NorLock divider planks are designed to withstand the most demanding industrial and agricultural environments. Planks have more density per square foot than competitors — meaning they don't need reinforcement — and can withstand the extra weight of equipment, shelving, and other items directly fastened to them. The non-porous surface of the heavy-duty panels are also easy to clean and maintain, all while being high impact resistant.

Applications: Commercial Agricultural

FLAT TOP/BOTTOM

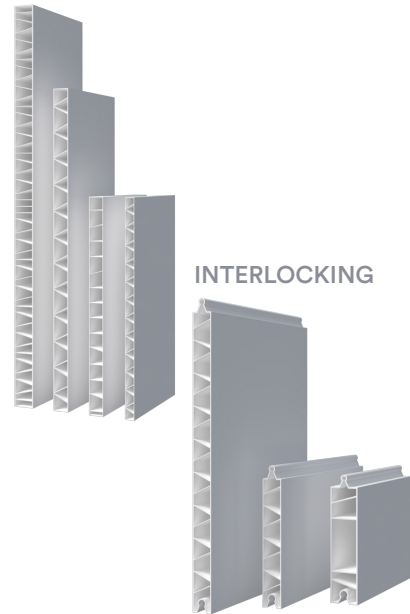

Features & Specifications

- Planks come in a variety of sizes and interlocking panels have a tight fitting, tongue-and-groove system with no external support necessary
- Available in multiple widths and lengths, including one-piece creep for hog applications
- Planks can withstand the extra weight of equipment, shelving, and other items fastened directly to them
- High impact tested
- Provides complete protection against the growth of bacteria, fungi, and viruses (ISO 846:2019)
- Low VOC compliant per the California Department of Public Health Standard Method v1.2 testing standard
- "Class A" fire rating (ASTM E84/ULC S102)
- CFIA, USDA, and FDA compliant for walls and ceilings

INTERLOCKING

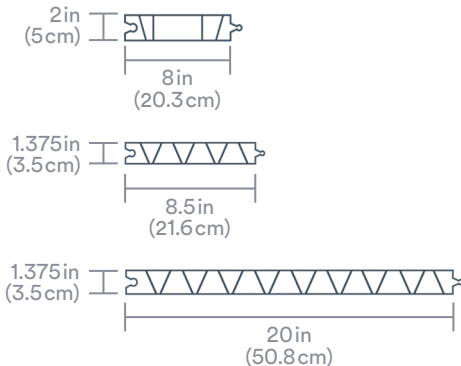

FLAT TOP/BOTTOM

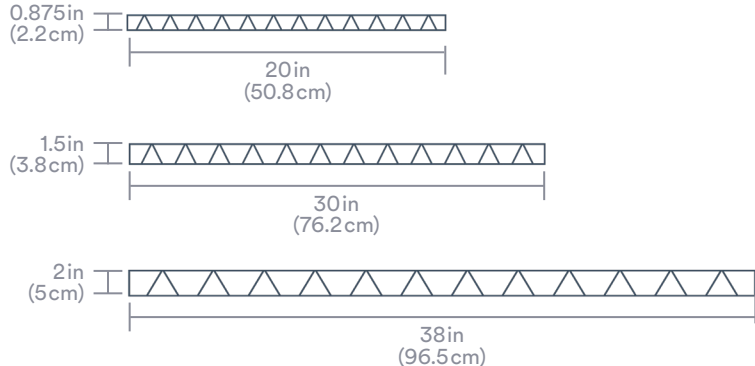

PANEL TYPE	WIDTH	HEIGHT	LENGTH	PRODUCT #
Interlocking	2in (5.0cm)	8in (20.3cm)	20ft	NL2035020
			24ft	NL2035024
	1.375in (3.5cm)	8.5in (21.6cm)	20ft	NL2203520
			24ft	NL2203524
		20in (50.8cm)	20ft	NL5003520
			24ft	NL5003524
Flat Top/Bottom	0.875in (2.2cm)	20in (50.8cm)	20ft	NL5082221
			24ft	NL5082224
	1.5in (3.8cm)	30in (76.2cm)	20ft	NL7503820
			24ft	NL7503824
	2in (5.0cm)	38in (96.5cm)	20ft	NL9655020
			24ft	NL9655024

Creep Nursery Finish

Trusscore® Trims

Framing Trims

Trusscore offers four trims that are designed to frame wall, window, and door perimeters, and to accommodate product transitions.

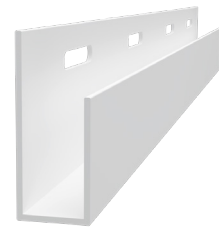

1/2" J Trim

A perimeter trim for Trusscore Wall&CeilingBoard installations in any application.

Use for:

- Top and bottom of walls
- Window and door perimeters
- Inside corners

LENGTH	COLOR	PRODUCT #
10ft	White	TCT12J10
	Gray	GTCT12J10

- Wall&CeilingBoard
- SlatWall
- RibCore

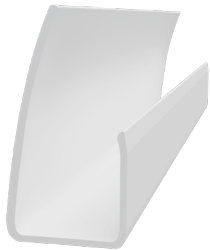

3/4" J Trim

A perimeter trim for Trusscore SlatWall and RibCore by Trusscore installations.

Use for:

- Top and bottom of walls
- SlatWall framing
- Inside corners

LENGTH	COLOR	PRODUCT #
10ft	White	RCT34J10
	Gray	GRCT34J10

- Wall&CeilingBoard
- SlatWall
- RibCore

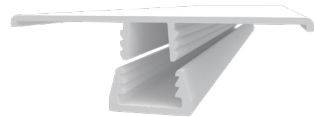

H Channel Snap-In Kit

A two-piece trim designed to accommodate panel expansion or contraction and product transitions.

Use for:

- Panel joints
- Product transitions

LENGTH	COLOR	PRODUCT #
10ft	White	TLT58WTC10K
	Gray	GTLT58HC10K

- Wall&CeilingBoard
- SlatWall
- RibCore

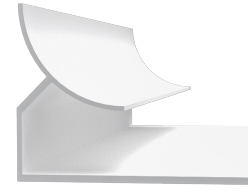

Inside Cove Corner

A clean, stylish option to complete the inside corners and wall perimeters of your project.

Use for:

- Inside corners
- Top and bottom of wet walls

LENGTH	COLOR	PRODUCT #
10ft	White	TCT12IC10
	Gray	GTCT12IC10

- Wall&CeilingBoard
- SlatWall
- RibCore

Finishing Trims

For a smooth and seamless finish, use these Trusscore trims to address outside corners, window and door perimeters, and to top off a Trusscore SlatWall assembly.



Outside Corner Rounded

Designed to form smooth, bullnosed outside corners for applications that require a softer touch.

Use for:

- Outside corners

LENGTH	COLOR	PRODUCT #
10ft	White	TCT12IO10
	Gray	GTCT12IO10

- Wall&CeilingBoard
- SlatWall
- RibCore



SlatWall Top Cap

A finishing trim for the top of a Trusscore SlatWall panel assembly that prevents dust and dirt from accumulating behind your panels.

Use for:

- Top of SlatWall installations

LENGTH	COLOR	PRODUCT #
8ft	White	TLT58J08
	Gray	GTLT58TC08

- Wall&CeilingBoard
- SlatWall
- RibCore

Outside Corner

A trim designed to address 90° corners and perimeters. Available in small and large sizes.

Use for:

- Outside corners
- Window and door perimeters

LENGTH	COLOR	WIDTH	PRODUCT #
10ft	White	1 1/4in	TCT12OC10
		2in	TCT12LOC10
	Gray	1 1/4in	GTCT12OC10
		2in	GTCT12LOC10

- Wall&CeilingBoard
- SlatWall
- RibCore

Specialty Trims

Every Trusscore installation is unique, and some will require special considerations and specialty trims to complete. For bottom wall transitions, angled wall- and ceiling-to-ceiling transitions, and soffits and bulkheads, these Trusscore specialty trims have your project covered.

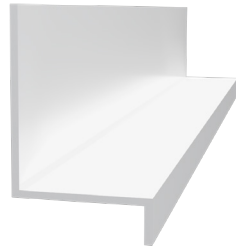

Base Trim

A transition trim that can be used to address the transition between wall panels and a concrete floor of a room.

Use for:

- Bottom wall transitions
- High moisture environments

LENGTH	COLOR	PRODUCT #
10ft	White	TCT12BT10
	Gray	GTCT12BT10

- Wall&CeilingBoard
- SlatWall
- RibCore

45° H Channel

A transition trim for installations where two walls come together at an angle.

Use for:

- Angled ceiling-to-ceiling transitions
- Angled wall-to-ceiling transitions

LENGTH	COLOR	PRODUCT #
10ft	White	TCT124510
	Gray	GTCT124510

- Wall&CeilingBoard
- SlatWall
- RibCore

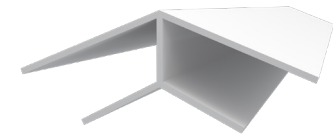

F Trim

A trim for specialized Trusscore Wall&CeilingBoard applications that include soffit or bulkheads, and for completing corners of RibCore installations.

Use for:

- Soffit and bulkhead transitions
- Inside and outside corners of RibCore installations

LENGTH	COLOR	WIDTH	PRODUCT #
10ft	White	0.5in	TCT12F10
		0.75in	RCT34IC10
	Gray	0.5in	GTCT12F10

- Wall&CeilingBoard
- SlatWall
- RibCore

NorLock™ by Trusscore® Trims & Accessories

For NorLock installations, Trusscore offers a range of compatible trims and accessories to help meet your unique commercial and agricultural project needs.

U Channel

A quick and simple way to cap the edges of NorLock wall assemblies. It ensures the vertical rigidity of the walls.

Use for:

- Securing panels to floors, walls, ceilings

LENGTH	WIDTH	PRODUCT #
20ft	0.875in	NL00UC78
	1.375in	NL00UC35
	1.5in	NL00UC201.5
	2in	NL00UC203

H Channel

The H Channel is designed to accommodate any expansion or contraction of the panels to preserve the installation of your project.

Use for:

- Joining panels

LENGTH	WIDTH	PRODUCT #
20ft	0.875in	NL00HC78
	1.375in	NL00HC3520
	2in	NL00HC220

U Channel 2 Piece

The two-piece U Channel is an efficient way to connect NorLock panels to edges and ceilings.

Use for:

- Walls and ceilings

LENGTH	WIDTH	PRODUCT #
20ft	1.375in	NL00UC235K

Note: Front face comes in two 10ft pieces for ease of handling

Corner Channel

The Corner Channel is used for inside or outside corner applications.

Use for:

- Corners

LENGTH	WIDTH	PRODUCT #
20ft	1.5in	NL50NFC20

Top Cap

The Top Cap is a profile that caps the top of a NorLock interlocking panel with a flat surface.

Use for:

▢ Interlocking cap

LENGTH	WIDTH	PRODUCT #
20ft	1.375in	NLNLPL3520CAP

End Cap

The End Cap is designed to enclose the cut ends of panels to keep dirt, rodents, and insects out.

Use for:

▢ Capping cut ends

LENGTH	WIDTH	PRODUCT #
20ft	0.875in	NL00EC508

Drop Rod & Drop Rod End

The Drop Rod and Drop Rod End are combined to create a hinged door with NorLock panels

Use for:

▢ Creating hinged doors

LENGTH	ACCESSORY TYPE	WIDTH	PRODUCT #
20ft	Drop Rod	N/A	NL00DR35
	Drop Rod End	1.5in	NL00DRE35
		2in	NL00DRE50

NorLock Trim & Accessory Compatibility Chart

PANEL TYPE	PANEL WIDTH	U CHANNEL	U CHANNEL 2 PIECE	CORNER CHANNEL	H CHANNEL	TOP CAP	DROP ROD & END	END CAP
Interlocking	2in	✓					✓	
	1.375in	✓	✓	✓		✓	✓	
Flat Top/ Bottom	0.875in	✓			✓			✓
	0.5in	✓		✓	✓		✓	
	2in	✓			✓		✓	



trusscore

Stocking Dealer Program

Upgrading to a Trusscore stocking dealer opens up a world of opportunities for your business.

As a Trusscore stocking dealer, you'll experience a significant increase in sales volume, enhanced customer satisfaction, and access to a suite of comprehensive sales and marketing tools designed to support your growth. With Trusscore, you're not just selling a product; you're providing your customers with durable, versatile, and high-quality solutions for their building needs.



By maintaining inventory of Trusscore products, you position yourself as a reliable and responsive partner for your customers, ensuring prompt fulfilment of their project needs.

We encourage dealers to maintain a level of inventory that reflects their market demand and business objectives. At a minimum, a safety stock level is required and outlined below. This inventory stock is usually sufficient for smaller projects or urgent replacements. As dealers grow their Trusscore business, we suggest you expand your inventory levels to meet broader project requirements and capitalize on increased sales potential.

STOCKING DEALER MINIMUM INVENTORY REQUIREMENTS

TRUSSCORE WALL&CEILINGBOARD	COLOR	PRODUCT #	PALLET QTY	PCS/PALLET
10ft Trusscore Wall&CeilingBoard	White	TC1610	1	150
12ft Trusscore Wall&CeilingBoard	White	TC1612	2	150
16ft Trusscore Wall&CeilingBoard	White	TC1616	1	150
TRUSSCORE TRIMS	COLOR	PRODUCT #	BOX QTY	PCS/BOX
½" J Trim	White	TCT12J10	5	50
Inside Cove Corner	White	TCT12IC10	3	25
Large Inside Corner	White	TCT12LOC10	1	25
H Channel Snap-In Kit	White	TLT58WTC10K	1	20

SUPPORTING DEALERS

- Do not maintain inventory
- Place orders on demand
- Limited ability to fulfil orders quickly

- ✓ **Marketing Materials**
Access professionally designed marketing materials such as brochures, samples, and digital assets to promote Trusscore products effectively and facilitate engaging and informative customer interactions.
- ✓ **Training & Support**
Take advantage of training programs and ongoing support from our team to ensure your staff is equipped with the knowledge and expertise to effectively sell Trusscore products.
- ✓ **Retailer Visibility**
Capture attention with a map pin and listing in the "Where to Buy" search results, guiding customers to your location.
- ✓ **Eye-Catching Display Board**
Install a visually appealing 2'x4' display board showcasing Trusscore products, capturing customer attention and driving sales.
- ✓ **Targeted Advertising Partnership**
Benefit from targeted advertising campaigns within a 25km radius of your location, driving local awareness and foot traffic.

STOCKING DEALERS

- Maintain inventory
- Immediate availability to meet customer demand and fulfil orders promptly

- ✓ **Marketing Materials**
Access professionally designed marketing materials such as brochures, samples, and digital assets to promote Trusscore products effectively and facilitate engaging and informative customer interactions.
- ✓ **Training & Support**
Take advantage of training programs and ongoing support from our team to ensure your staff is equipped with the knowledge and expertise to effectively sell Trusscore products.
- ✓ **Prominent Retailer Visibility**
Stand out with a highlighted map pin and top-ranking listing in the "Where to Buy" search results, directing customers to your stocking location.
- ✓ **Distinctive Product Showcase**
Choose from customizable or free-standing display options to feature Trusscore products, enhancing product visibility and driving conversion.
- ✓ **Targeted Advertising Partnership**
Benefit from targeted advertising campaigns with higher investment within a 25km radius of your stocking location, driving local awareness and foot traffic.
- ✓ **Profitable Pricing Structure**
Gain access to exclusive volume pricing, maximizing margin opportunities and ensuring competitive pricing for your customers.
- ✓ **Tailored Stocking Profile Page**
Showcase your stocking status with a customized profile page on our "Where to Buy" map, featuring a striking header image and comprehensive store details.
- ✓ **Co-Branding Opportunities**
Collaborate with Trusscore on co-branded marketing initiatives to enhance your brand visibility and reach new customers.
- ✓ **Brand Engagement Package**
Enjoy a branded swag package including hats, pencils, and more to enhance your store's identity and foster customer loyalty.
- ✓ **Enhanced Customer Satisfaction**
With readily available inventory, stocking dealers can meet customer needs promptly, leading to increased satisfaction and loyalty.

Sell 3x More Product!
Stocking Dealers experience a **significant boost in volume** compared to non-stocking dealers.

Looking for more resources?



Trusscore Retailer Hub

The Trusscore Retailer Hub is a one-stop-shop for retailers and distributors where you'll find product knowledge sessions, estimation resources and videos, sales tools, competitive analysis, and more. It's also where you can order any additional Trusscore product samples or in-store merchandising you need when it's time to stock up.



Trusscore Installation Help

The Trusscore Installation Help page has the answers to all your customers' installation questions. Here you'll find detailed guides, QuickStart guides, and tips videos designed to help your customers navigate our DIY-friendly installation process.

Contact Us

Need something else? The Trusscore team is only a phone call or an email away. Contact us directly — we're happy to help.

 1-888-418-4679

 hello@trusscore.com



hello@trusscore.com | [1.888.418.4679](tel:18884184679) | trusscore.com

Copyright © 2023 Trusscore Inc. Trusscore, Trusscore Wall&CeilingBoard, Trusscore SlatWall, NorLock by Trusscore, RibCore by Trusscore, and Trusscore Trims are trademarks of Trusscore Inc. All other trademarks are the property of their respective owners.

Specifications are subject to change. T-BR109-002 04/2024

