

# OUTDOOR

## Ladder Ball Game Plans

Great fun game to setup at your next BBQ or outdoor event.

### Board Cut Diagram

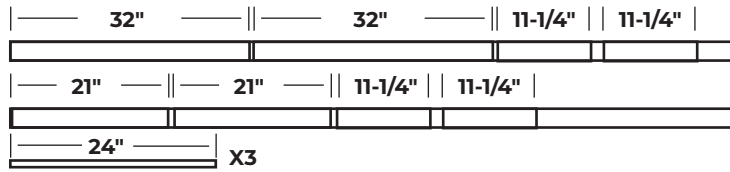

### Tennis Ball Bola



### Front View

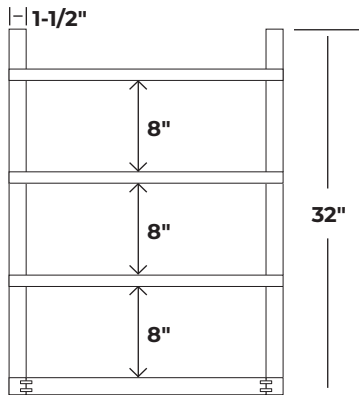

### Side View

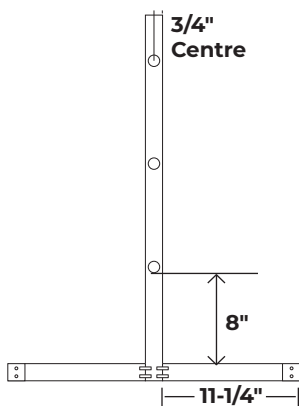

### Top View

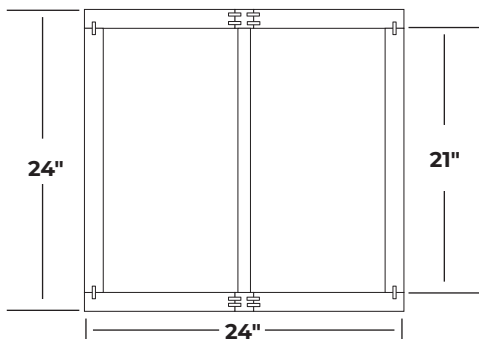

### Tools:

- Miter Saw or Hand Saw
- Pencil
- 1" Drill Bit
- 1/4" Drill Bit
- Drill
- Hammer
- Measuring Tape
- Clamps



### Materials List:

Material	Quantity
2 x 2 x 8'	2 Boards
1" x 24" Dowel	3
1/4" Dowel Pins	24
Tennis Balls	16
Rope	Approx 6'
Paint/Finish	Personal Preference

### Build Instructions:

1. Start by trimming off the rough end of the 2 x 2 boards with your miter saw.
2. Follow the cut diagram for the producing all the pieces required.
3. Use your 1/4" drill bit to create holes for the dowel pins as indicated. Take care to make sure the holes for each pin line up on both boards.
4. Cut the 1" holes through the two vertical legs of the ladder as indicated. Clamping the two pieces together and drilling through both pieces will help keep the rungs level.
5. Dry fit all the pieces together to make sure everything works and then use wood glue on the dowels and rungs during final assembly.
6. Paint as you like.
7. Use a clamp to hold a tennis ball in place and use your 1/4" drill bit to drill all the way through each ball.
8. Cut your rope so there is approx. 6" of space between the balls once you thread it through each ball and tie knots at each end as seen in the diagram.